

Crafting Change



Govan's children, raising their voices for the future
of our planet

A wee introduction...

This project started with a survey, carried out amongst children at Govan HELP's daily breakfast club in Govan's Pirie Park and St Saviours Primary Schools. We wanted to find out what children knew about climate change and how they felt about its impact on their futures. We learned that even primary aged children have a strong awareness of climate change, and feel very anxious about what it means for their futures. This came as a shock to the adults who support them, as children we never worried whether we would still have a planet to grow up in. At the same time, our children are incredibly resourceful and creative. When we asked what needed to be done to protect our planet, they all spoke about the importance of care, protection and sustainability.

From experience we know that there is nothing our children love more than to be presented with a load of junk to up-cycle into beautiful crafts and artworks. Lockdown and the school closures meant we had to

redesign our original proposal. It made the project even more important though, giving parents and children resources to get creative and something unrelated to the pandemic to think about. We launched a competition looking for Govan's craftiest kids, and handed out material packs in the local community alongside our newly launched food pantry project.

We were overwhelmed by the uptake, and received some absolutely beautiful entries, all of them spreading awareness of the cause. This booklet is about thanking those children, giving them a voice about the future of their planet and sharing some of their creative solutions to the problem that we face. Finally we couldn't have done this project without the support and guidance of The Glasgow Centre for Population Health, whose insight into the health impacts of climate change have been invaluable.

Javier, 7

"I believe that we must raise awareness about the damage we do to nature and to ourselves by not recycling. We should also help by not polluting the environment any more, and make our children aware from a young age how polluting our environment affects us, so that we will want to take care of our flora and fauna."



Conlan, 11



"I feel that climate change is bad for polar bears because it is ruining their homes. Co2 emissions are melting the ice. Temperatures are hotter because Co2 emissions are continuously increasing. Cutting down trees is wrong because trees absorb Co2 emissions from going into the atmosphere. We all need to work together towards helping reduce Co2 emissions."

Aalia, 13

"I think climate change is reality and we should be looking after our planet for our future generations."



Emma & Alice, 4 & 6

"I like summer, there is a good weather, mum often takes me out to play. I don't like winter, it's too cold. I like rainy days, because the rain will clean up a lot of places and sometimes I can see the nice rainbow."

Emma



"I like the rainbow after the rain, like the flowers in spring, like the snow in winter, like the colour of autumn - the leaves are yellow - I like the sky in summer, and nice sunshine."

Alice

Dean's Mini Football Pitch



You will need:
1 x paper cup
A pair of scissors
Some masking tape and craft tape
12 paper straws
Cardboard, and
coloured tissue paper

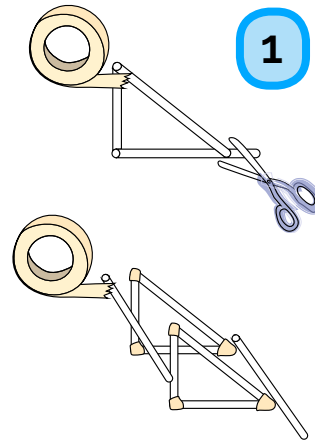
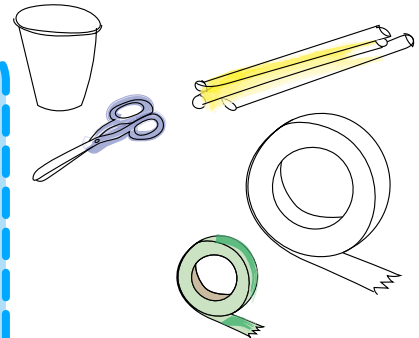

1

Make four triangles from your straws and tape them at the corners. Stand the triangles up and tape two other straws across the top and back of the goals.

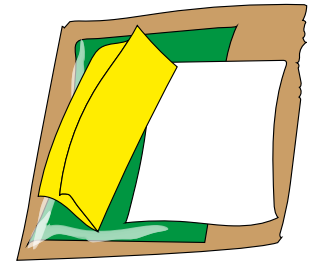

Trace around the back and sides of each of your goals. Then cut these out and glue them on to create the goal nets.

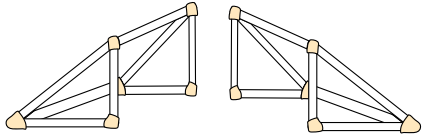

2

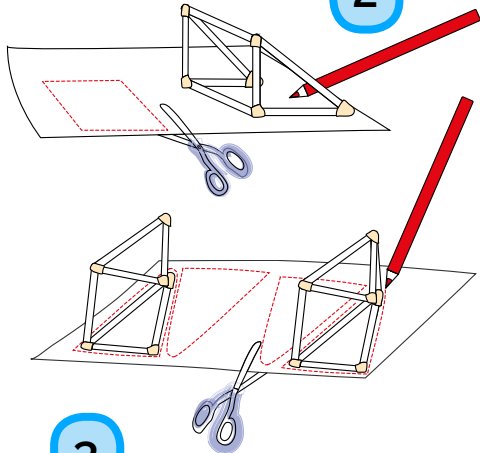

3

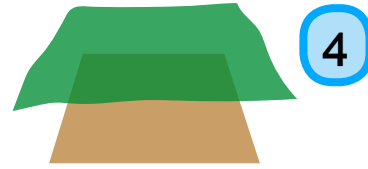
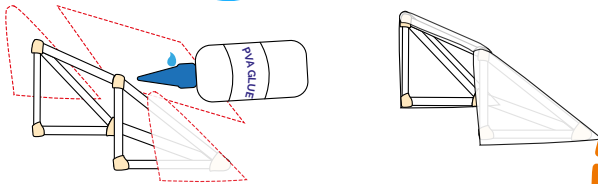

4

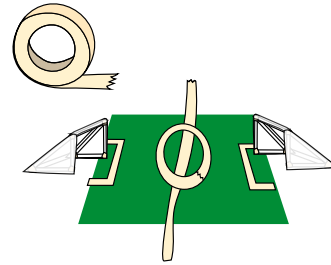

Cover your cardboard in green tissue and mark the goal lines with tape. Cut your paper cup in half to make two sets of benches, assemble your football pitch and blow the whistle!

5

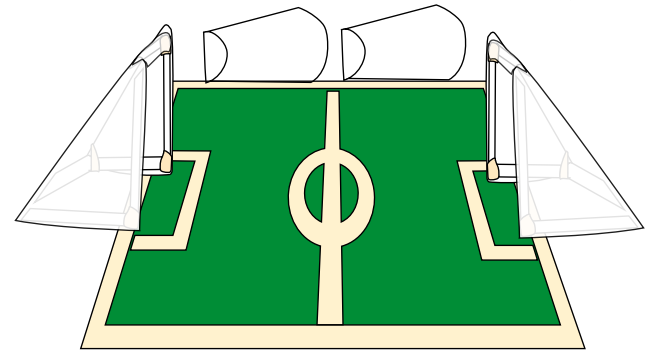
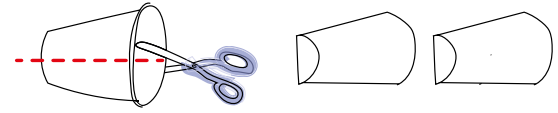

Oliwia & Wictoria, 7 & 13

"I'm sad that people make and use all sorts of mechanics that damage the earth. Many creatures are losing lives because of habitat lost due to forest burning from the hot sun. I wish that the first minister could tell everyone to stop ruining nature." *Oliwia*



"Climate change should be more frequently spoken of. If the younger generations don't know of it, our beloved earth may not survive. If we don't, the younger generation may follow in our steps and not help at all. Speaking is as important as taking action." *Wictoria*



Hana & Jan, 3 & 5

"We feel that all of us should do our own part for climate change, raising awareness and understanding of what our Planet actually needs from us. Our planet needs to feel our better side as an individual, and as humanity."



Arika



"We shouldn't cut down trees which give us oxygen to breathe, birds reduce in count because we cut the trees and destroy our forests. Emissions from industries and factories makes the climate horrible and polluted. Instead we should grow more trees and save our rain forests, don't use plastic and chemicals and make a habit to recycle more. Less emissions and healthier eating habits will help keep planet Earth liveable."

Omar and Hayaa, 9 & 6



★ How do you feel about Climate Change, Hayaa?

I feel we are still in danger, because the bad activities of factories and cars.

★ How do you feel about Climate Change, Omar?

I think countries must take action to protect our environment.

Thank you
Omar & Hayaa

Ayesha's Penguin Mailbox



"We have to take care of our planet because we don't have a planet B. We can do this by not cutting down trees and throwing our rubbish in the bin."

You will need:
A shoe box or cereal box
2 x paper cups
A pair of scissors
Glue & craft tape
12 paper straws
Cardboard, and coloured
tissue paper
Crayons

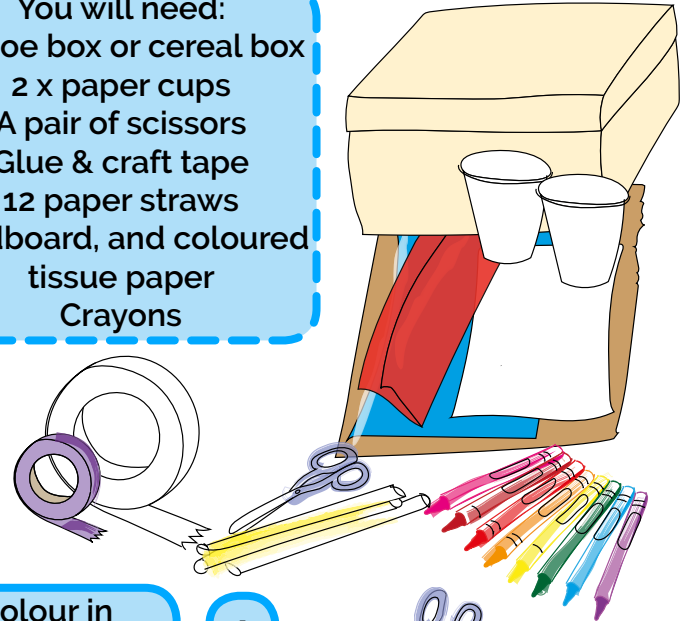

Colour in
your box and
mark and cut
out a letter box
three quarters
of the way up.
Ask an adult to
help with the
cutting.

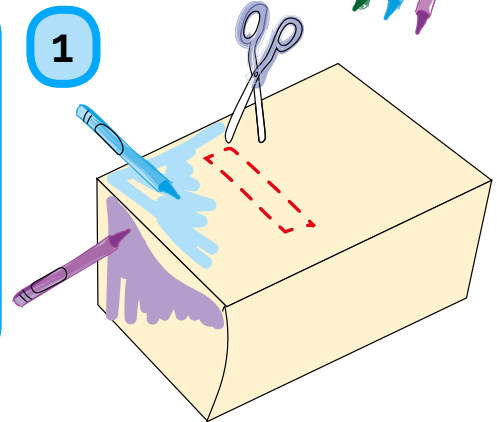

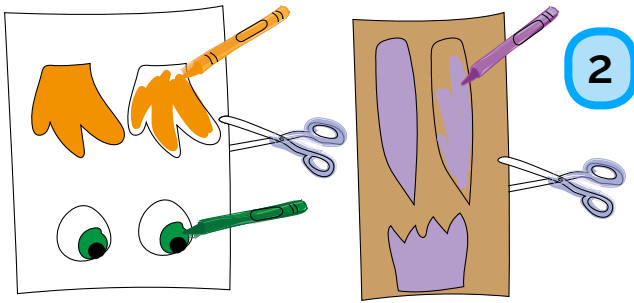

2

Draw two eyes and two feet on the paper, then two wings and a crest on the card, and cut them out. Glue the feet onto two paper cups and stick them to the bottom of your box. Turn your box round and stick the eyes, wings and crest on.

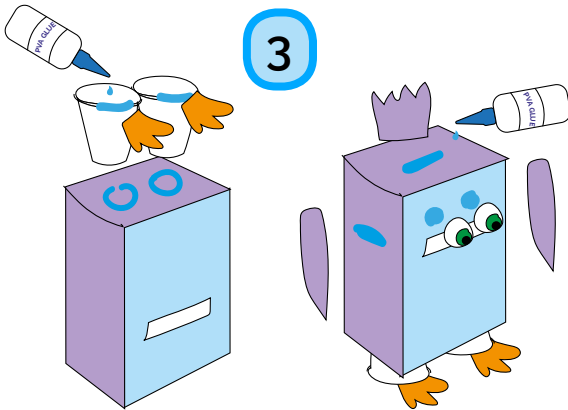

3

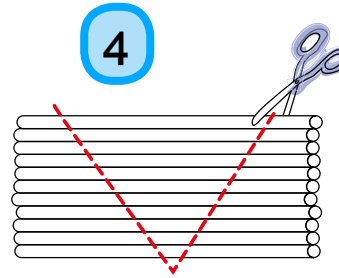

4

Line up your paper straws then, tape them together, then mark and cut it into a triangle. Colour it in yellow and glue just under your letter box.

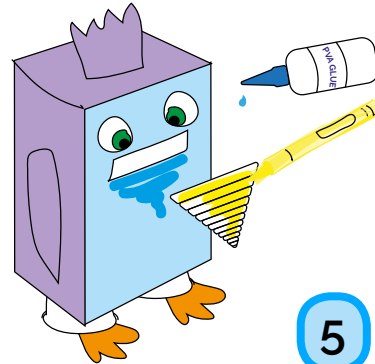

5

Finally decorate your box in whatever way you want, you could give it a bow or bow tie.

Now get writing your letters to post in your box!

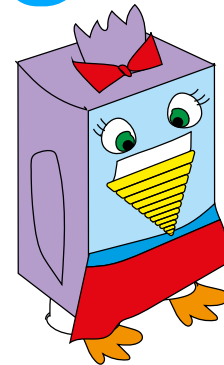

Simran, Radha & Gurveer, 7, 9 & 11



Haya, 5



"Climate changes make me anxious sometimes but I will work hard to preserve my environment and animals."

Bismah, Adil & Subhan, 10, 14 & 7

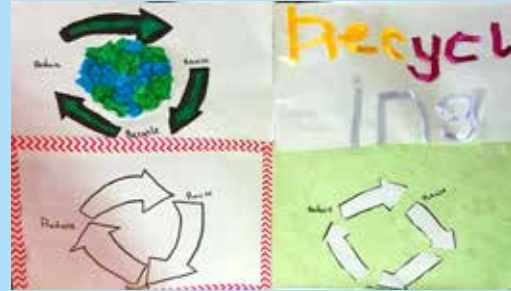

"I feel interested about climate change and scared because scientists say



that humans are responsible for climate change."

Bismah

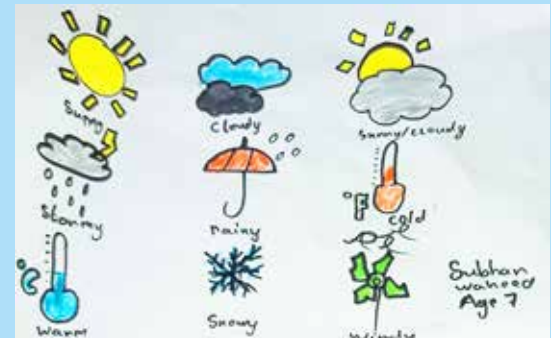

Subhan waheed
Age 7

The cover photograph is an artwork by Ryan, age 10.

**When asked how he felt about Climate change,
Ryan expressed his delight that everyone is
thinking about it, and gratitude to Govan HELP for
encouraging kids to promote a noble cause in this
difficult time.**

Thank you Ryan!

Govan HELP
Pearce Institute
840-860 Govan Rd,
Glasgow G51 3UU

0141 445 6481
hello@govanhelpp.org
www.govanhelpp.org

Scottish Charity Number SC 034834
Limited Company Number 256657

